

ENGRAVING DETAILS

ALL CHARACTERS TO BE RAISED 0.30
 NUMBERS TO BE 3.0 HIGH
 LETTERS TO BE 5.0 HIGH

THIS AREA TO BE INSERTED ON THE TOOL
 TO ALLOW THE CUSTOMERS NAME
 TO BE ENGRAVED IF REQUESTED

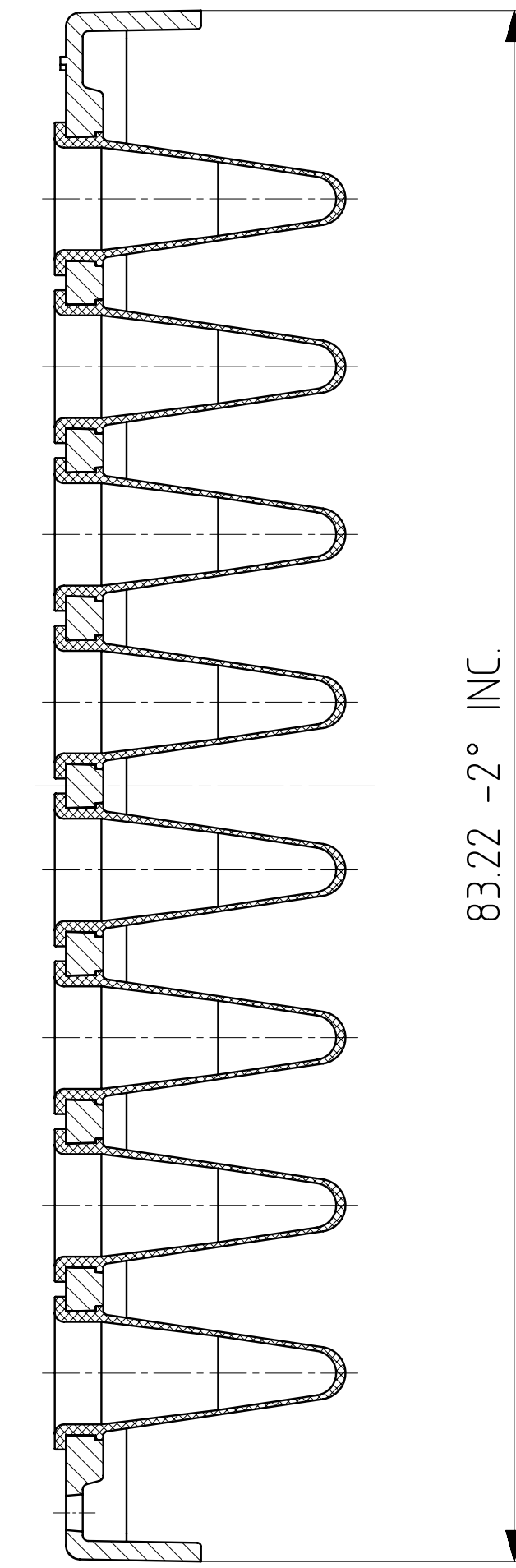
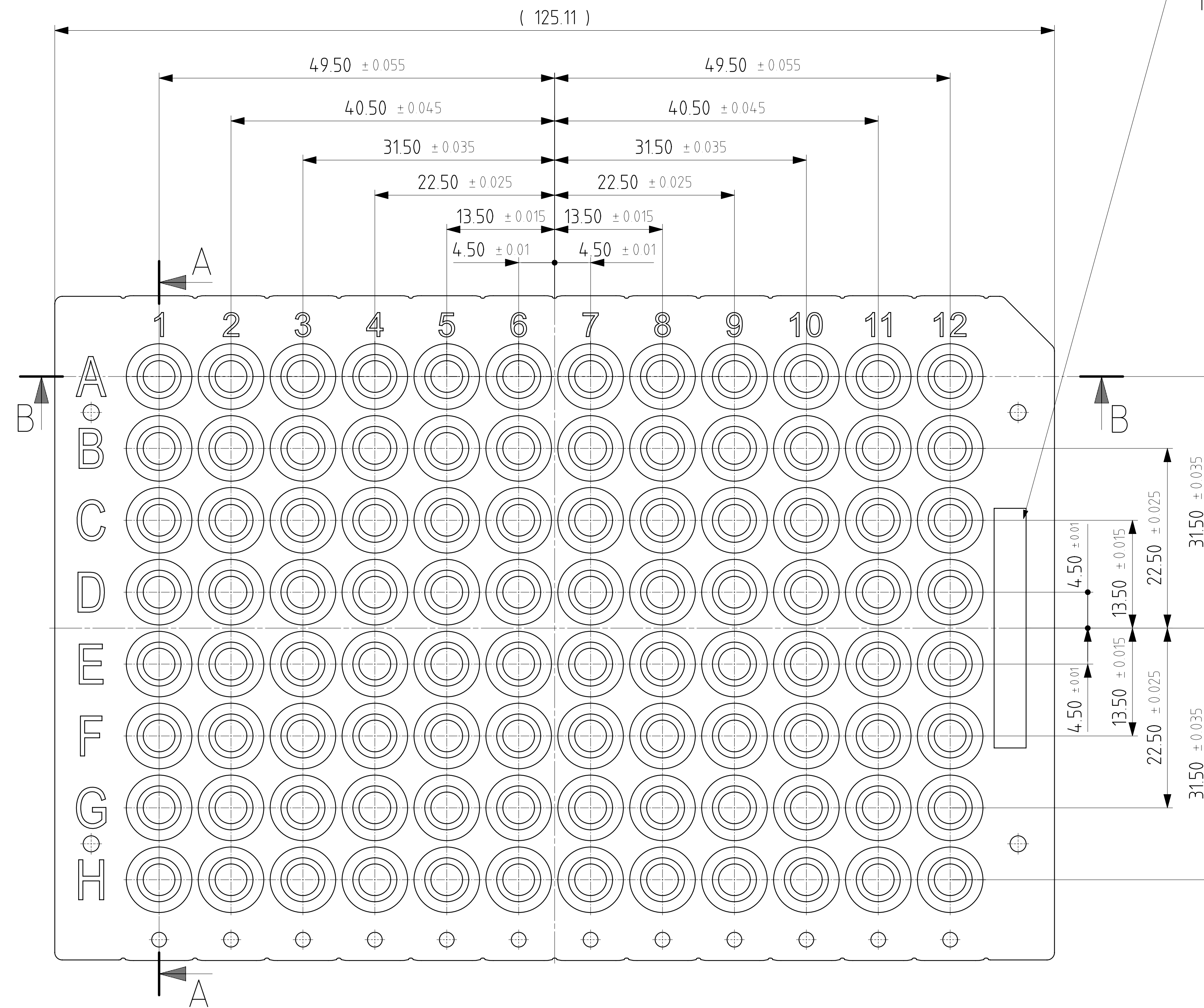
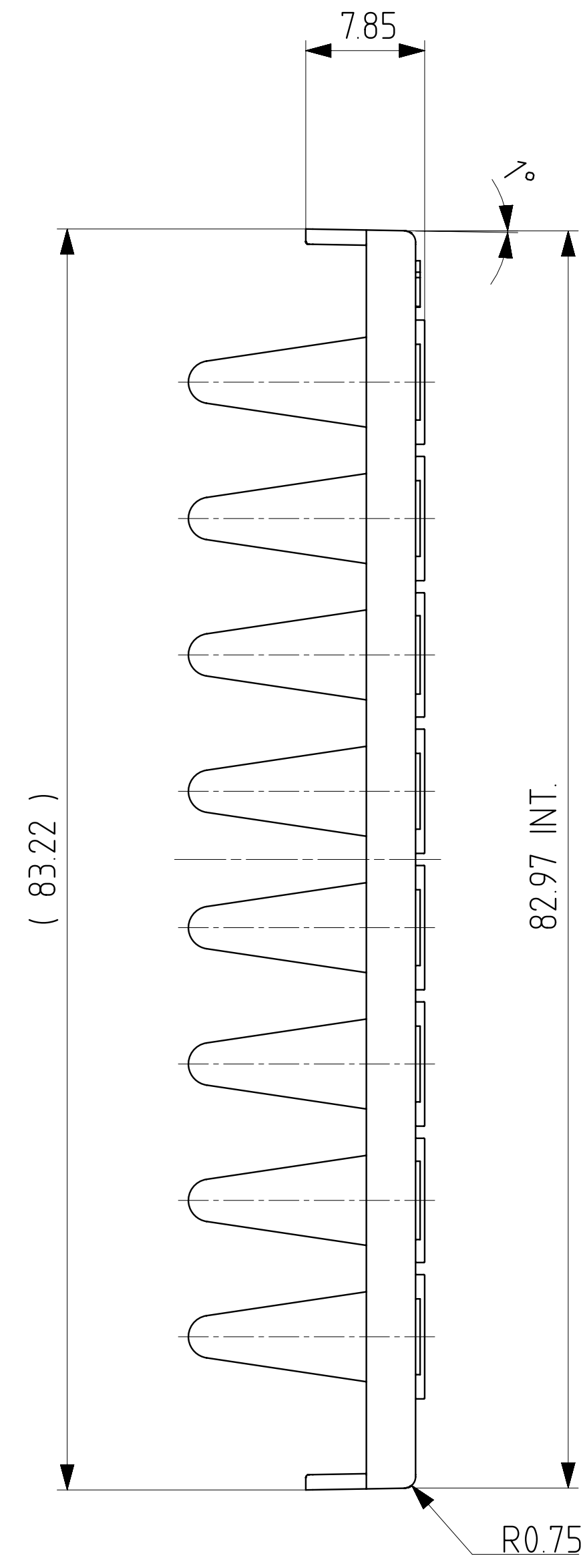

SECTION A-A

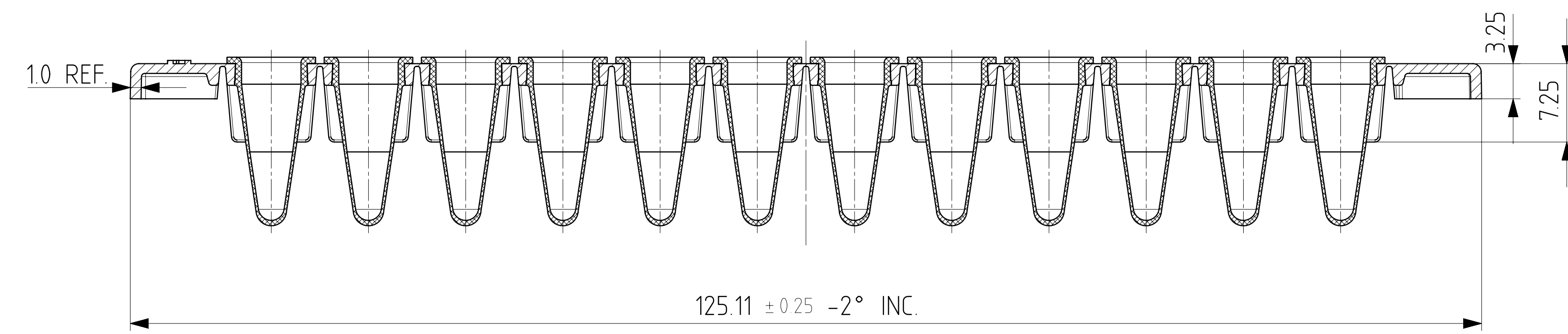

SECTION B-B

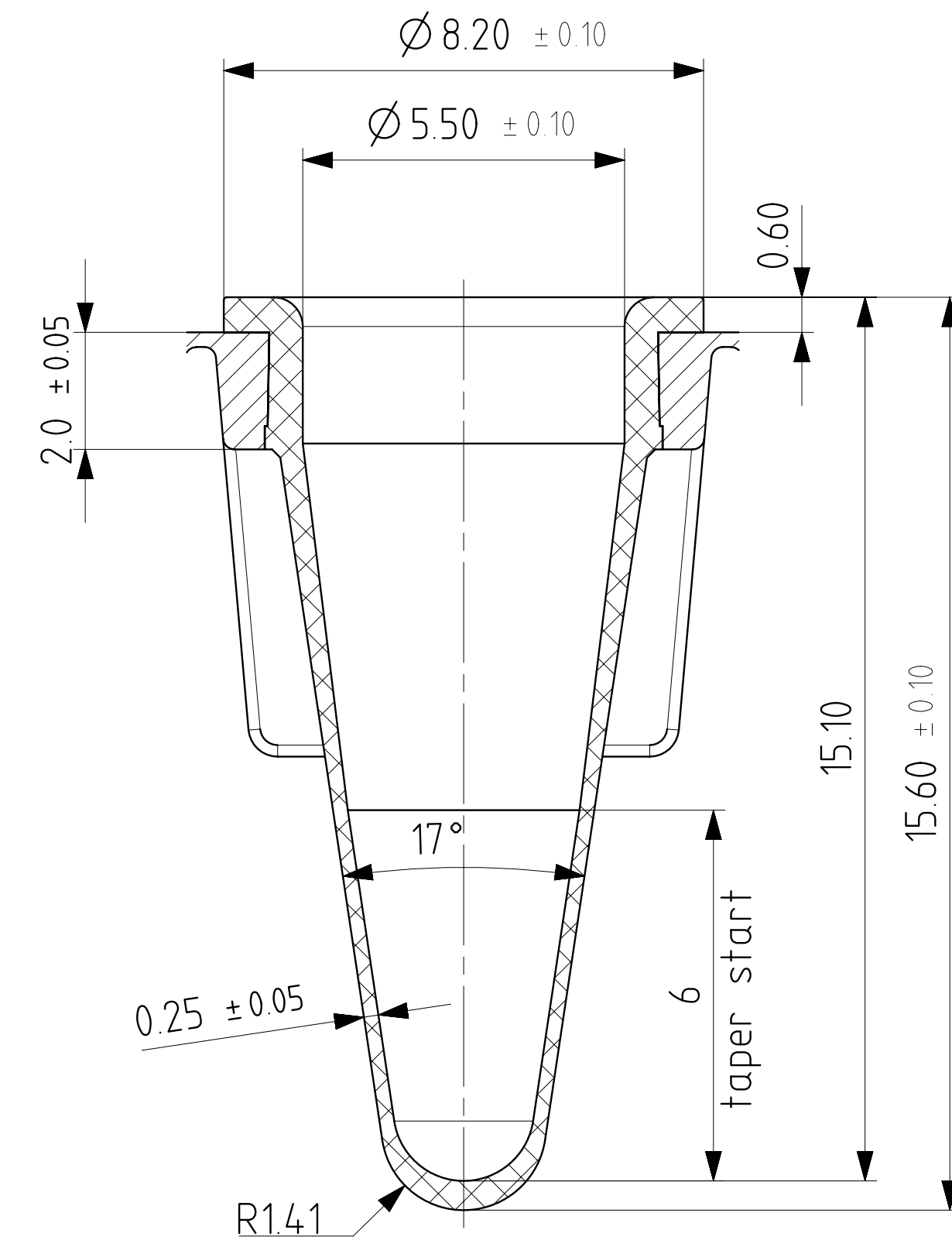

VIAL FORM 96 pos
 SCALE 10:1

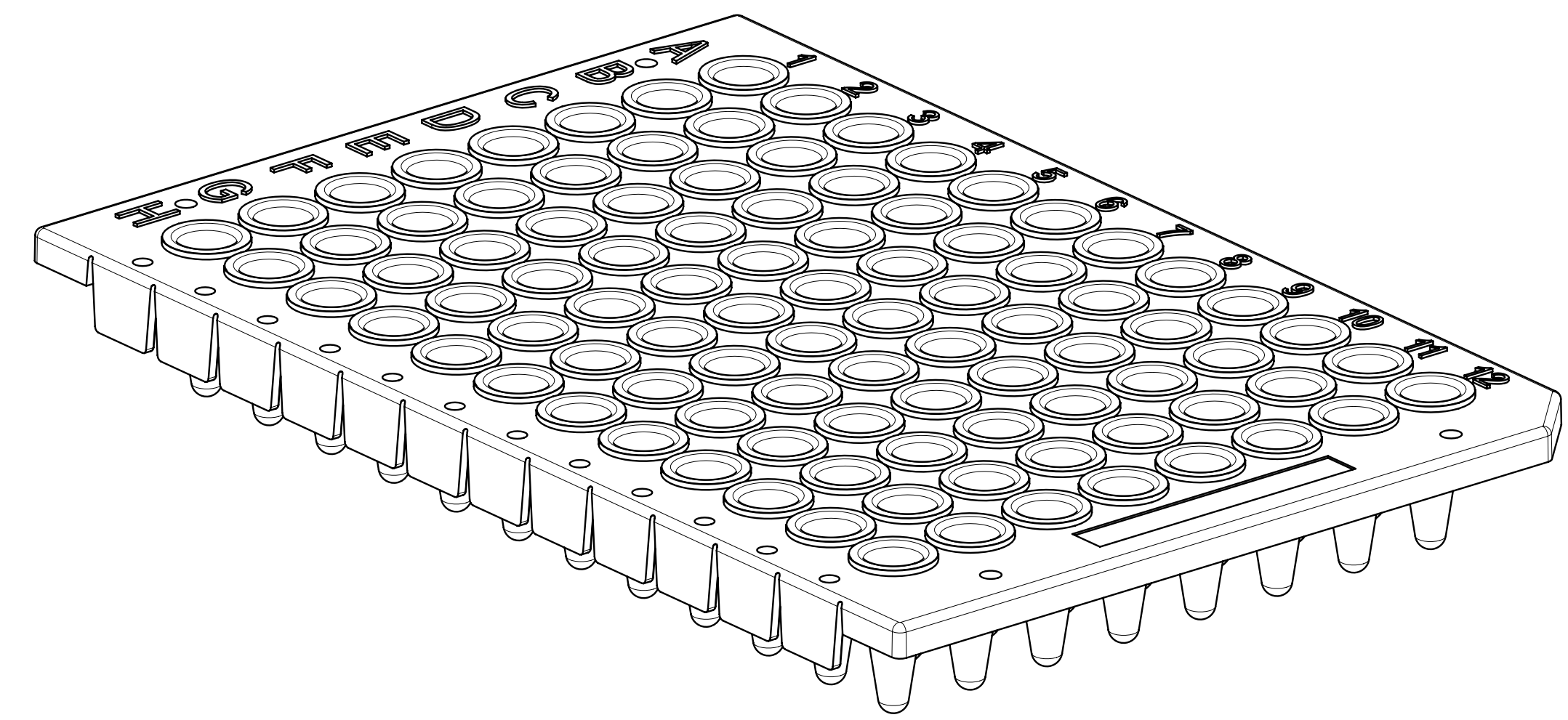

| ISSUE | DATE | AMENDMENT | ISSUE | DATE | AMENDMENT |
|-------|------|-----------|-------|------|-----------|
| | | | | | |
| | | | | | |
| | | | | | |
| | | | | | |
| | | | | | |
| | | | | | |
| | | | | | |
| | | | | | |
| | | | | | |
| | | | | | |



DO NOT SCALE
 IF IN DOUBT ASK

| | | | |
|------------|---|---------|------|
| CUSTOMER | CUSTOMER DRG No | ISSUE | DATE |
| MATERIAL | FRAME: polycarbonate, TUBES: polypropylene | CHECKED | DATE |
| TOLERANCES | 0 ±0.20 0.0 ±0.05 0.00 ±0.05 ANGULAR ±0.30° (ALL DIMENSIONS IN MILLIMETRES) | SCALE | |

| | | | |
|---------|------------|------------|--|
| DRAWN | ZOLTAN E. | TITLE | FRAMEstar® BREAK-A-WAY (short tube version) MARKETING DRAWING |
| CHECKED | JAMES B. | DRAWING No | 4ti-1200 |
| DATE | 21.10.2013 | SHEET No | 1 OF 1 |
| | | ISSUE | C |