

AZENTA
LIFE SCIENCES



**PARTNERS
IN SUCCESS**

Introduction to Ziath

Scanners for biobanking, compound management and other sample tracking applications

Avash Anderson- Product Manager

Wilbert Lennartz-Regional Sales Director Europe

March 2023



Ziath – The Company



Founded in 2005, Ziath develops innovative new products designed to simplify processes in life science organizations, from academia, to the biotech and pharma industries.

In particular, we focus on managing large sample libraries (compound management, biobanking and sample management) using 2D datamatrix tubes.

- Joined the Azenta Life Sciences Family 03/02/2023
- Based in Cambridge – UK
- Ziath has a range of products split into four main categories: 2D barcode scanners, devices for handling tubes, 2D barcoded tubes and sample management software.

Ziath Offices

Ziath LTD – UK – Main Office & Manufacturing Center

- Cambridge, United Kingdom
- T: +44 (0)1223 855021

Ziath BV – EU – European Office

- Brunssum, Netherlands
- T: +31 6 43141195

Ziath INC – North America

- San Diego, California – United States
- T: +1 (858) 880-6920

What is sample management?

- Selecting, collecting, storage and retrieval of samples and their inherent data.
- Until the 1970s, most laboratory samples were manually handled and managed; which subsequently encouraged the development of LIMs
- Any system that aims to streamline laboratory workflows by overseeing the management of its samples can be described as a LIMS.
- Modern sample management systems include tailored software and hardware that allow sample data to be accumulated and analysed.

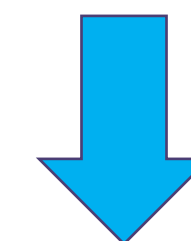

Why is effective sample management important?

- Without precise and careful sample collection, recording, and storage, confidence in the data can be compromised
- Barcode labels and scanners increase the accuracy of information entry
- Possibility of losing an entire sample database is eliminated
- Costly repeat experiments avoided and improved workflow efficiency
- Integrating single tube and rack scanners allows improved tracking and tracing

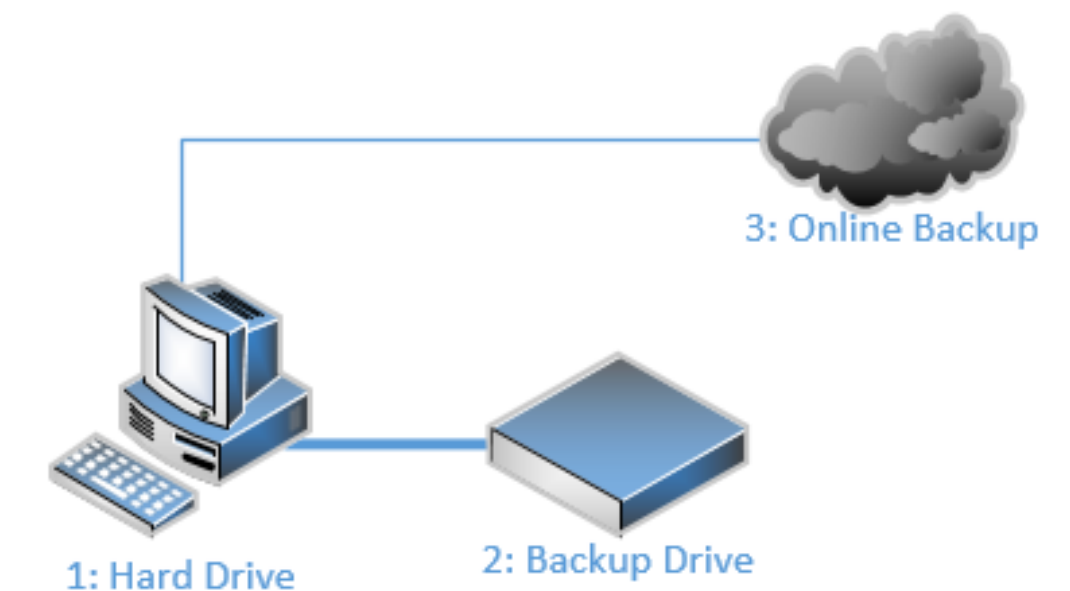

Why use barcodes to track your Samples?

- 2D barcodes on the base of tubes allow for multiple tubes to be scanned in seconds
- 2D Data Matrix Code is not a QR CODE!
- Recommended to use CODE 128 linear barcodes for racks
- Scanning barcoded tubes is an efficient way of logging a sample's unique ID in a LIMS
- Parameters such as location, expiry data, sample type etc can be recorded.



Data Matrix Code



QR Code



C o d e 1 2 8

Understanding Biobanks

Old definition

- The term biobank is relatively new. It appeared in PubMed for the first time in 1996 (Loft & Poulsen, 1996).
- Used to describe various biological repositories, it originally referred to large population banks of human tissue and related data.

Current definition

- Now covers collections of plant, animal and human specimens.
- The data associated with stored biospecimens have increased in complexity

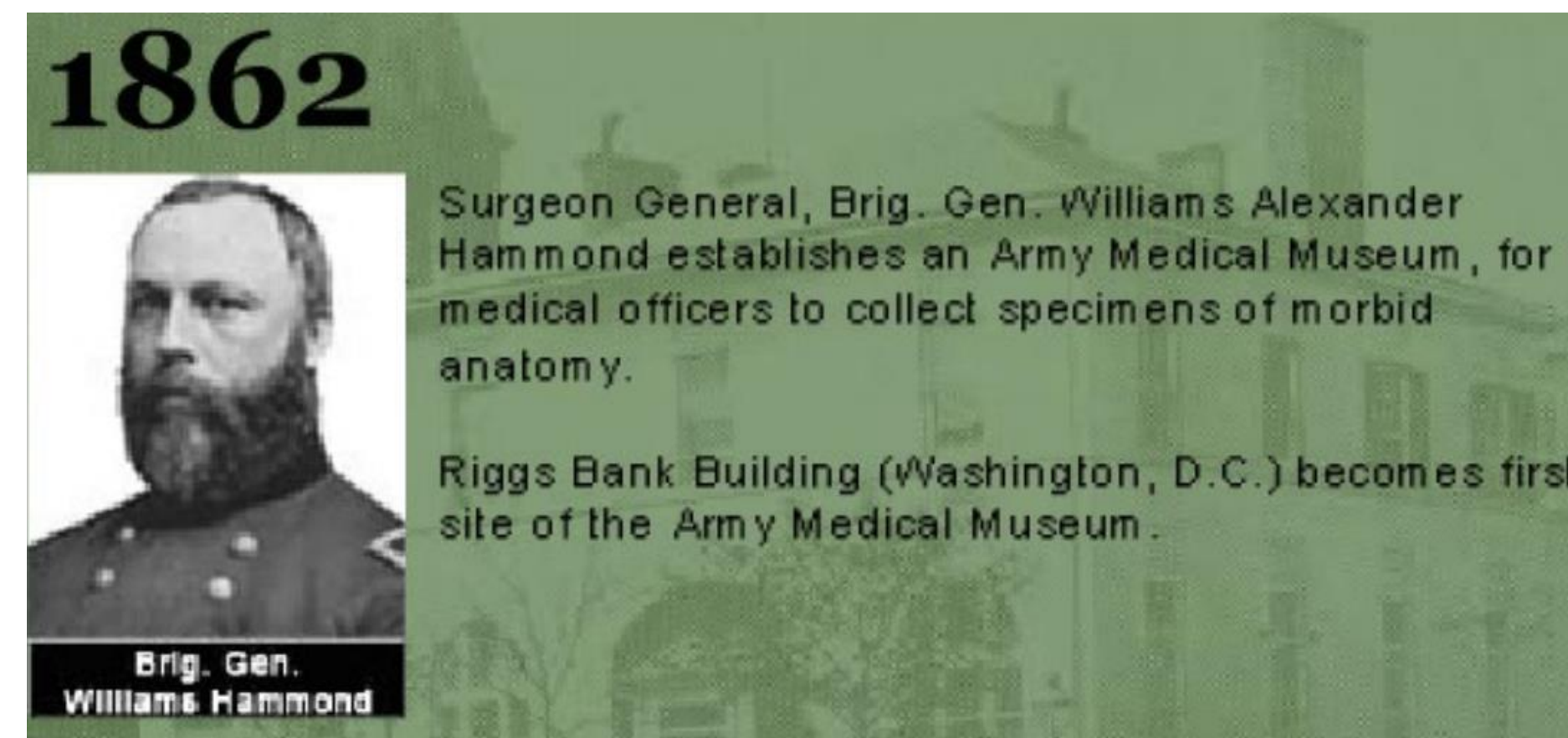

Compound Management

- Drug discovery – different chemicals are assayed for their activity
- These chemicals are stored as physical quantities in a chemical library
- Libraries are used in high-throughput screening in the drug discovery hit to lead process
- Chemical libraries in larger pharmaceutical companies are a critical part of the discovery process
- Chemicals are stored in environmentally controlled conditions in small or large containers, ideally this would be in 2D barcoded tubes in SBS format racks.
- Management of these chemical libraries = compound management

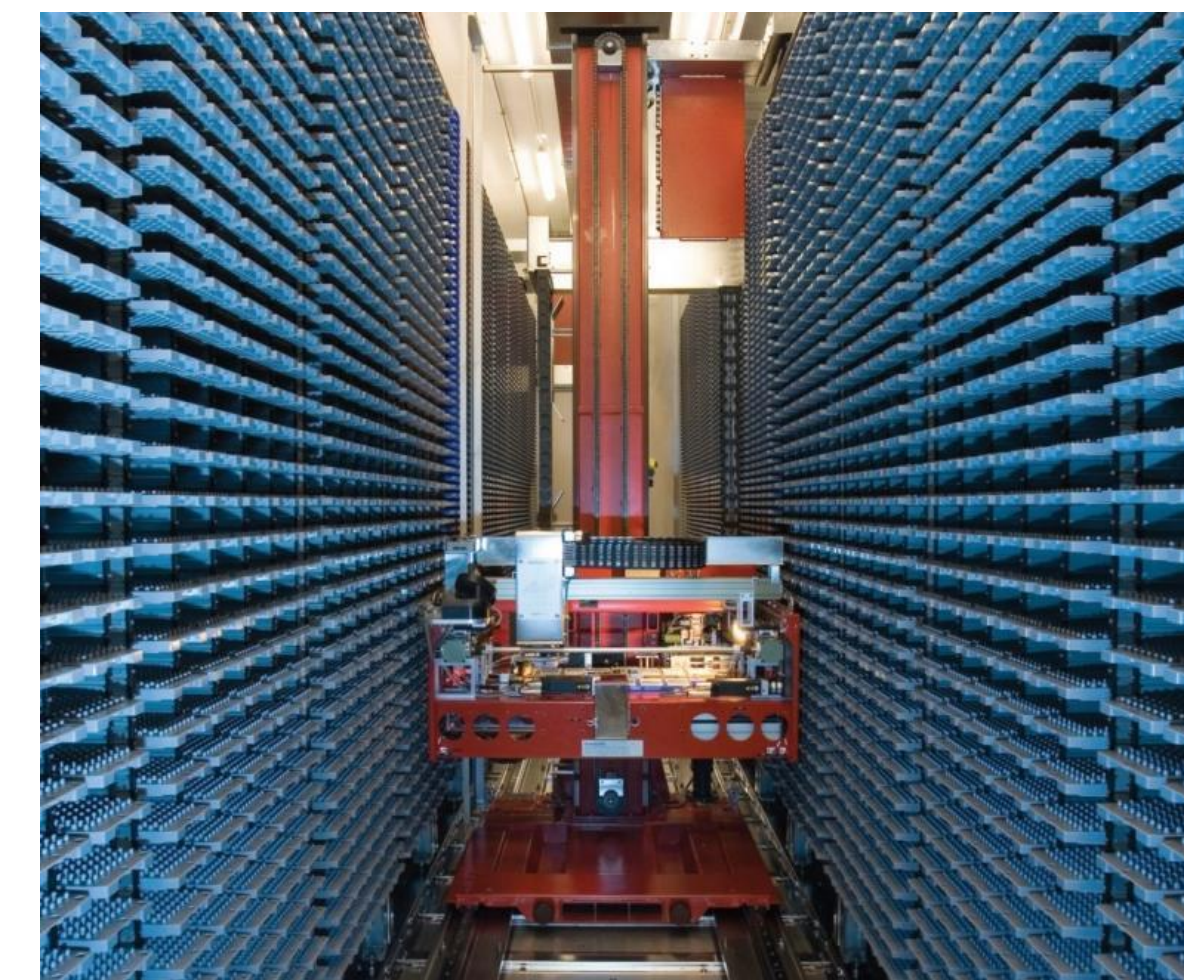



Other applications

Diagnostic Testing

- 2020-2022 large part of our business
- 300 Cube Scanners to IAEA for Covid Testing
- Testing programs used the Cube in their RT-PCR program
- Sanger Institute, UK Genomic Consortium, all over Czech republic and more

Plant and Animal Genomics

- Increase in 2D coded tubes as the solution

Other applications

- Epidemiology studies, transfusion medicine, Forensics, Cannabis Testing, Real and Lab Grow Meat testing, agriculture testing.



Uno/Duo

- Fast scanning of 2D tubes
- Strong mineral glass window
- 'Keyboard Wedge' setting allows data entry directly into your application
- Compatible with all 2D Data Matrix tubes
- Comes with Uno/Duo software (not compatible with DP5)

Options

Cryoprotection™ - available all on all readers/scanners



Uno



Duo

Cube

- Fast camera-based scanner – solid state CMOS camera with scan speeds of up to 1 second
- Versatile scanner capable of scanning all SBS tube rack formats and larger cryoboxes
- No set-up required, scanners are pre-calibrated
- Patented LED illumination system & optics allows imaging under difficult conditions
- 24, 48, 96, 138, 240, 384 SBS
- 81, 100, 196 CRYOBXES



Cryoprotection - cold rack scanning option

Cyclops Available

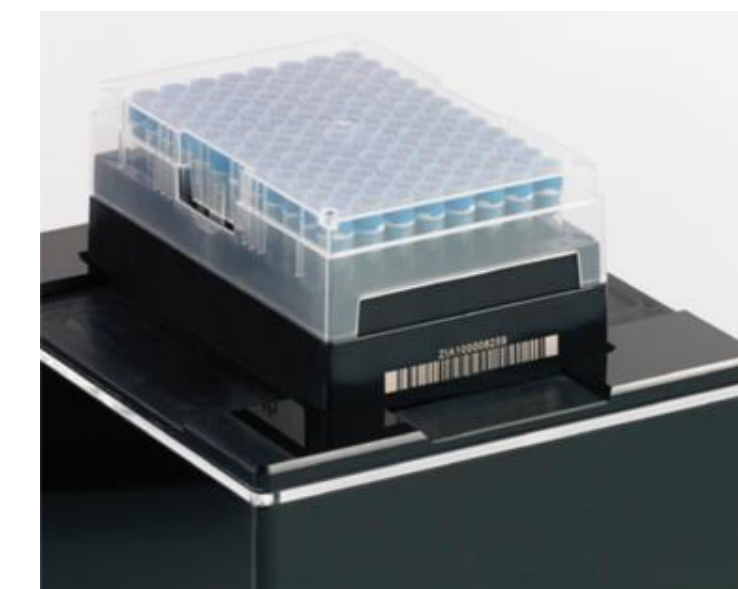

Versatile



Mirage

- Cost effective alternative to a traditional flatbed scanner
- Low-profile and compact design
- Laboratory benchtop or even liquid handling workstations
- Compatible with most SBS racks – 24, 48, 96, 240 but not 384
- Scan and decode in 1-2 seconds
- Can manage strong overhead lighting.

Cryoprotection - cold rack scanning option

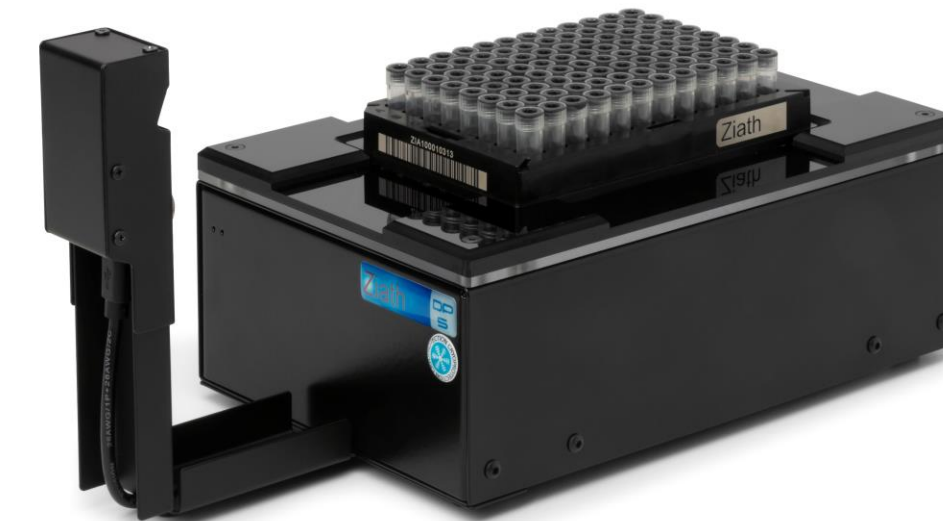

Cyclops Available

Cost-effective



PARTNERS
IN SUCCESS

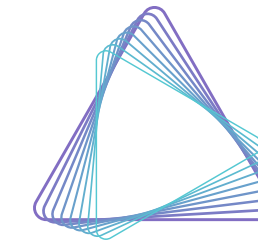

AZENTA
LIFE SCIENCES

Express

- Smallest footprint 2D barcode rack scanner
- Patented technology allows imaging under difficult lighting conditions
- Fast camera-based scanner
- Ideal for integration within large automated systems
- Capable of scanning all SBS Rack formats
- 24, 48, 96, 240, 384 SBS tube racks

Cryoprotection - cold rack scanning option



Cyclops Available

Integration



Unique selling points – Cube/mirage/express

Other advantages Ziath scanners have over competitors

- Competitor scanners will struggle to read a single tube in a rack
- More export options compared to all of our competitors, we can now export in 9 ways in DP5: Excel/CSV, Text, HML, JSON, PDF, Image, Database, python and email
- Our scanners simply arrive and you can set it up with a click of a button; other scanners need lots of complicated setup, which can take many hours
- Our cryoprotection is passive and works with multiple racks straight from -80.
- For integration we provide integration libraries and free training via Teamviewer or some other remote session software from the programmers who wrote the software.
- We design, program, build, test, sell and support our own scanners - nobody else does that. The reason that this is important is because if you have a question, you will get an answer from the team who built it.



DP5 Standard software

DP5 Standard simplifies day-to-day scanner operation, it runs like any other desktop application from a connected PC or laptop

- Runs all Ziath camera-based scanners
- Export options: We are now up to 9 export options – Excel/CSV, Text, XML, JSON, PDF, Image, Database, Python and Email.

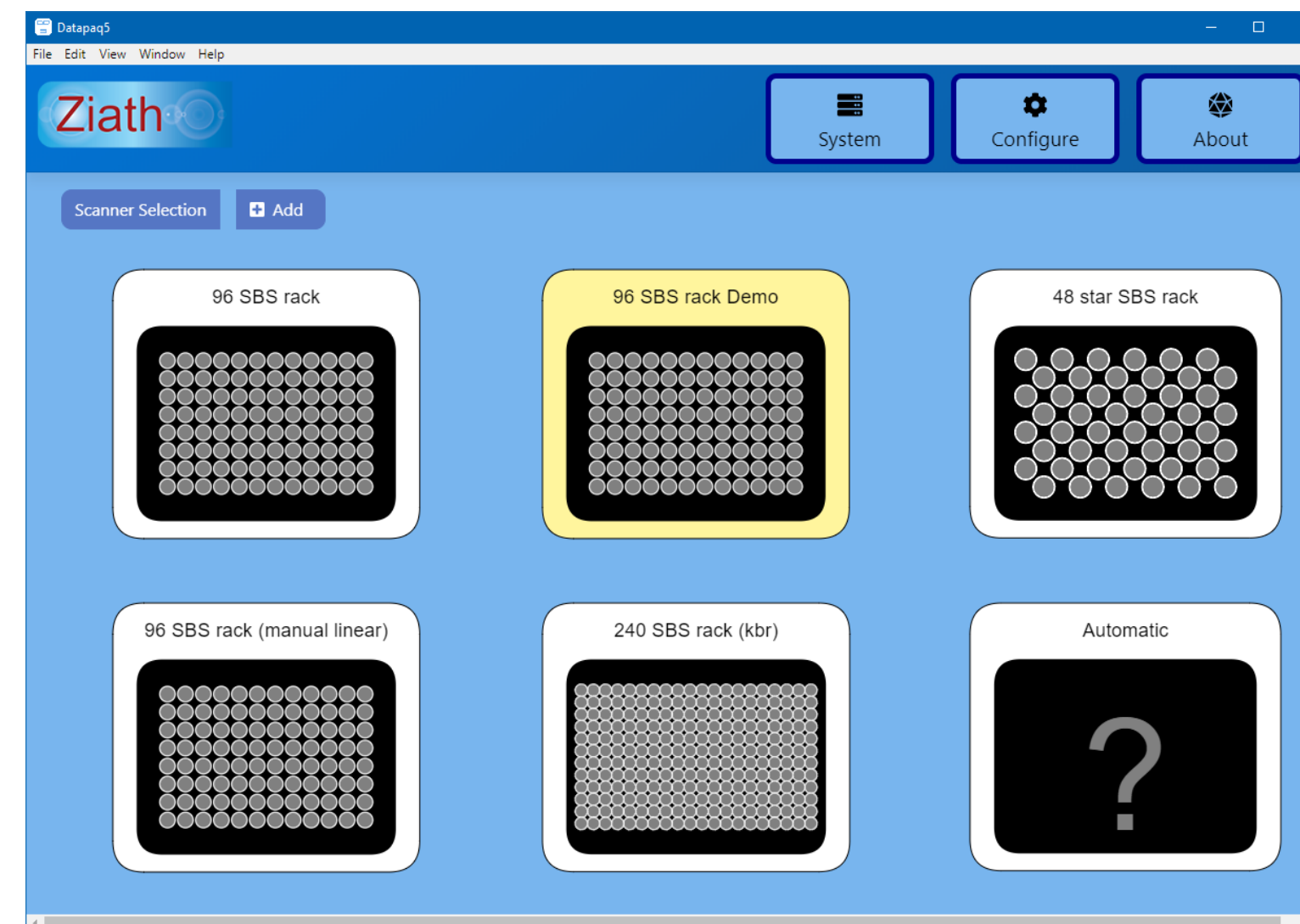



PARTNERS
IN SUCCESS

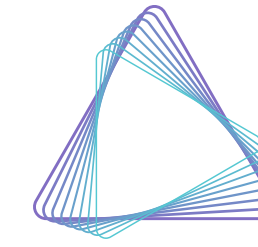

AZENTA
LIFE SCIENCES

DP5 Standard continued

Scan time questions can be added with-in the software

Scan time questions

Who ran this scan?

What study is this from?

Continue

	A	B	C	D	E	F
1	Container Id	Row	Column	Barcode	Who scan?	What study?
2	LVL100074986	A	1	LV1007674971	Lab user 1	XC1000
3	LVL100074986	A	2	LV1007674907	Lab user 1	XC1000
4	LVL100074986	A	3	LV1007674988	Lab user 1	XC1000
5	LVL100074986	A	4	LV1007674942	Lab user 1	XC1000
6	LVL100074986	A	5	LV1007675000	Lab user 1	XC1000
7	LVL100074986	A	6	LV1007674861	Lab user 1	XC1000
8	LVL100074986	A	7	LV1007674953	Lab user 1	XC1000
9	LVL100074986	A	8	LV1007674913	Lab user 1	XC1000
10	LVL100074986	A	9	LV1007674926	Lab user 1	XC1000
11	LVL100074986	A	10	LV1007674858	Lab user 1	XC1000
12	LVL100074986	A	11	LV1007674921	Lab user 1	XC1000
13	LVL100074986	A	12	LV1007674940	Lab user 1	XC1000

DP5 Standard continued

Template specific settings
Scanner and export settings can be defined for an individual template.

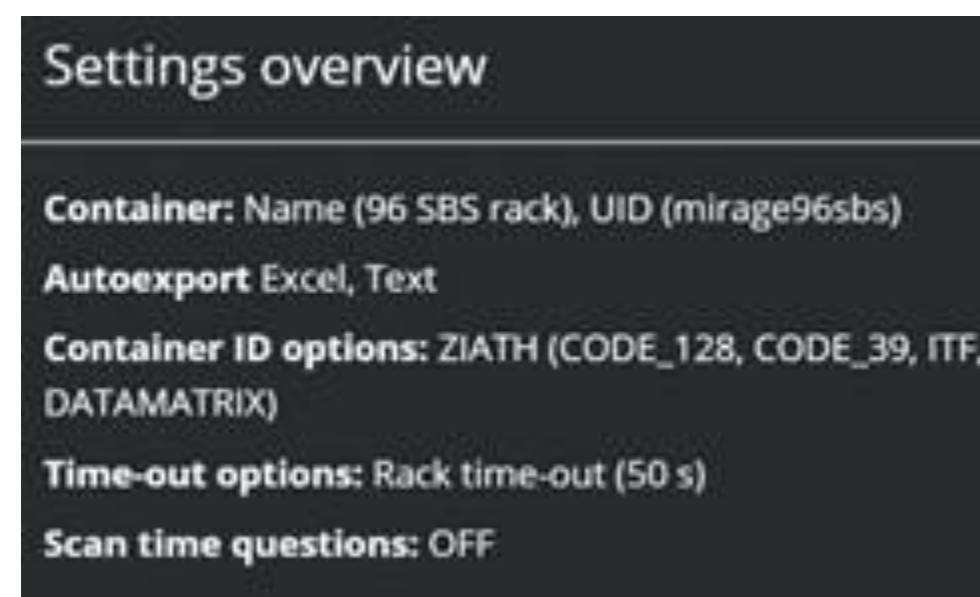

Modify settings for the template, export a 96 SBS rack in Excel & Text and use the linear barcode on the side of the rack.

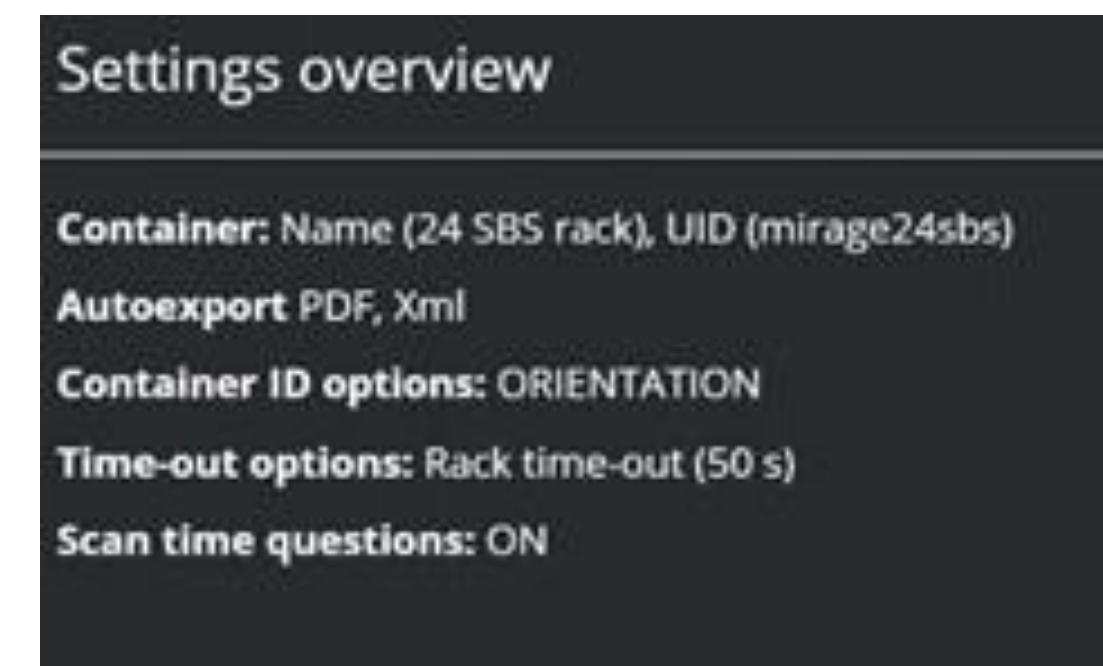

For another template, export in PDF & XML and use the orientation barcode.

DP5 NETWORK SOFTWARE

DP5 Network unchains you from the bench, allowing a scanner to operate anywhere on your LAN from your own tablet or phone, even right alongside your freezers.

- Advanced operation via a LAN allows scanners to be controlled directly from a Wi-Fi connected phone, tablet, desktop PC or laptop.
- Control multiple scanners on one server from one hand-held device, laptop, tablet or desktop computer.
- Scripting feature allows high level of post-run data processing automation – send files to LIMS, e-mail, Excel or any other compatible program
- Take a scanner anywhere on site, run a scan on a hand-held device and send that file back to any computer in a variety of formats

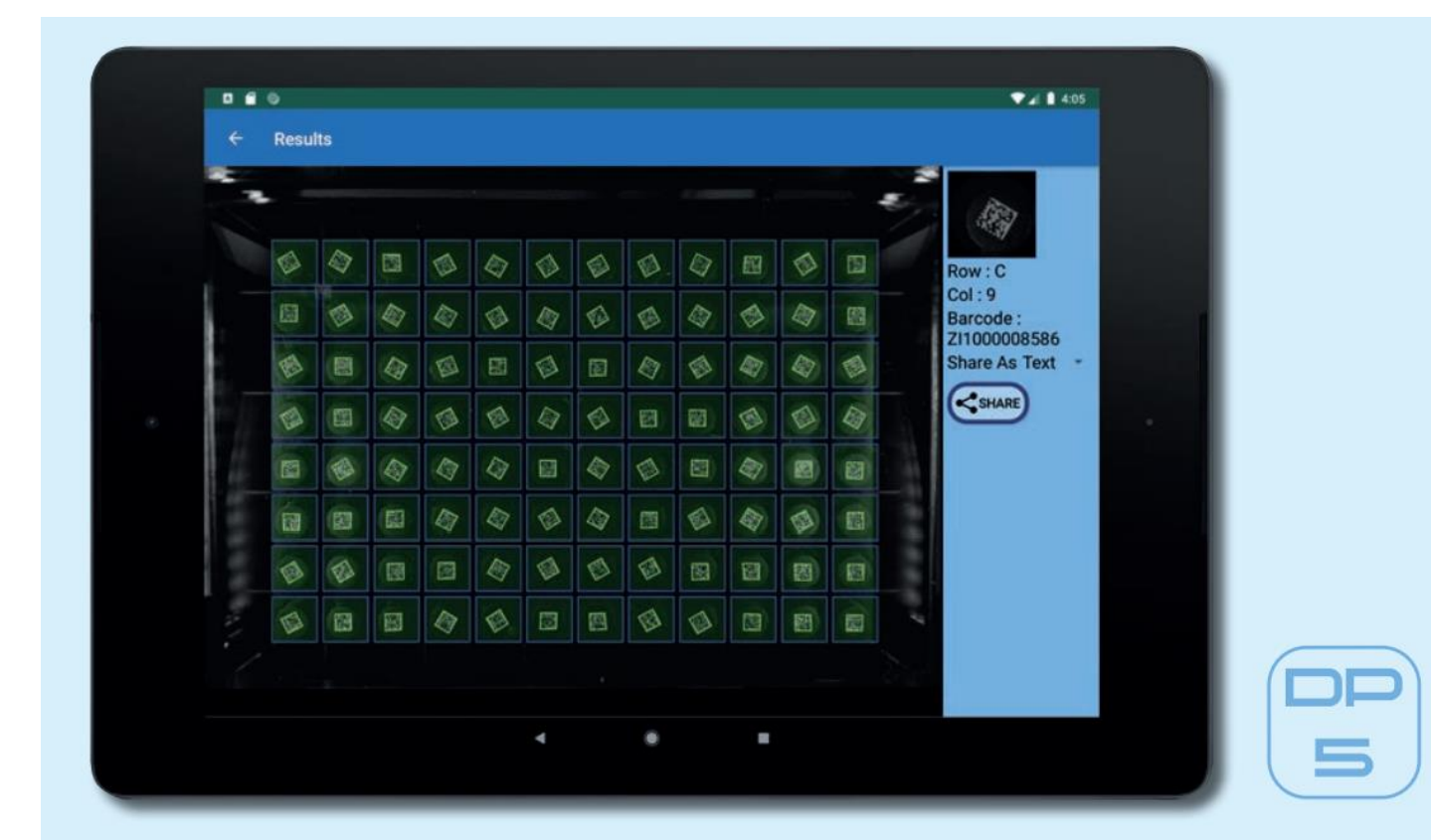
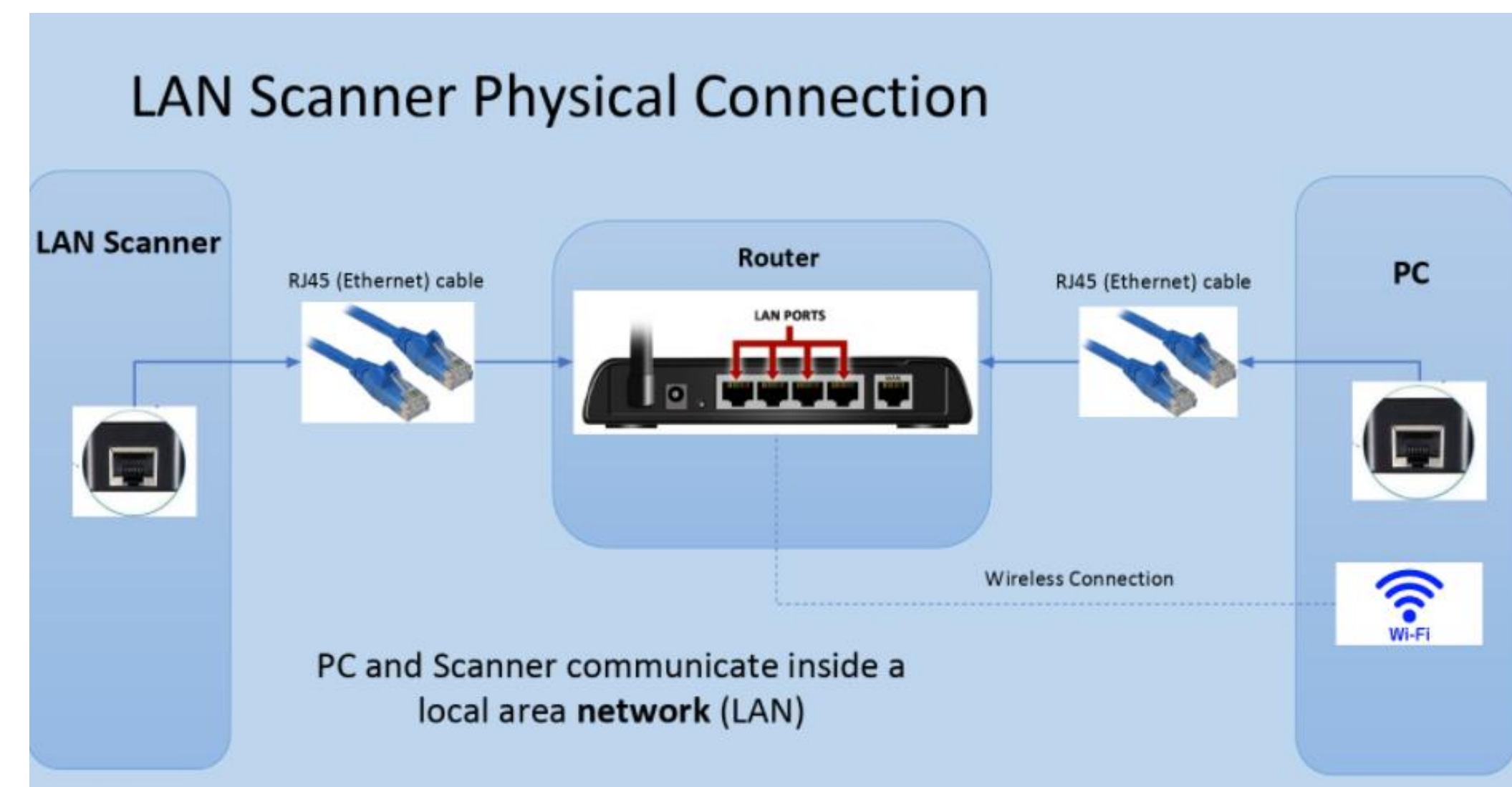

DP5 NETWORK continued

Standalone vs LAN Scanners

Standalone Scanner

- Communication through the **Scanner – PC network**
- Scanner creates the network
- **Only the connected PC** can operate the scanner through **DP5/DataPaq**

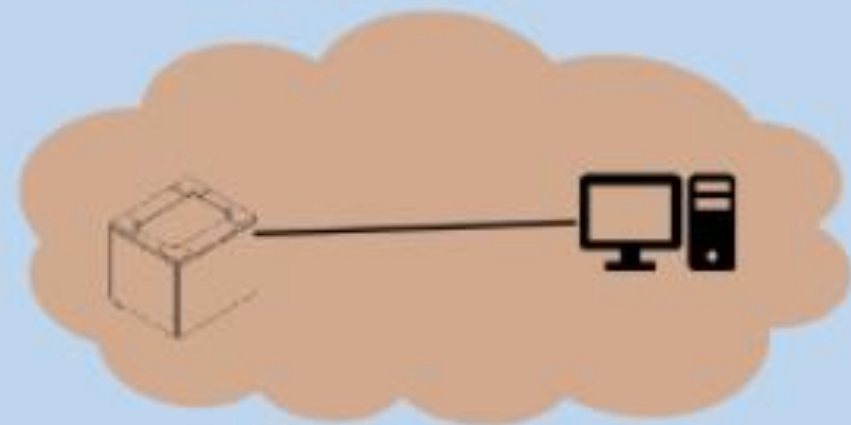

LAN Scanner

- Communication through the **office network** (aka LAN/Intranet/...)
- Router creates the network
- **Any device in the network** can operate the scanner through **DP5**



Scanner Standalone vs LAN connector types

	RJ45 (Ethernet) Connector	USB Connector
DP5	LAN Scanner	Standalone Scanner
DataPaq 3	Standalone Scanner	Standalone Scanner
* Special cases { DP5 (Custom Client Order)	LAN Scanner / Standalone	Standalone Scanner
DataPaq 3 (Mirage LAN Tecan)	LAN Scanner / Standalone	Standalone Scanner



DP5 API documentation

For DP5 we have a RESTful interface plus sample code in Java, C#, Python and Go with a Swagger interface.

User Guide



Mohawk Semi-automated tube picker 48 & 96

- Fast and reliable tube picking from 96 position racks
- Low profile lid adapter for small volume tubes
- Works with frozen and thawed tubes
- Create picklists in excel, csv, text, xml or json
- Add a 2D barcode scanner for tube confirmation and for generating picklists directly from the tube barcodes
- 1D scanner for rack barcode included as standard



Operation

Automatic Mode

Designed to allow for operation of the Mohawk with minimal interaction on control PC

Worklist File

A file that describes the tubes that are to be selected, there are multiple formats available



Handheld2 – Portable scanner

- Compatible with all known 2D Datamatrix tubes
- Portable, independent and compact
- Cryoprotection comes as standard
- Scan tubes standing in the basement, at the freezer or liquid nitrogen tank
- Battery life of up to a week with casual use



Handheld- modes

Five operating modes:

- Simple scan
- Scan and display data
- Pick list
- Edit/Add data
- Wired keyboard wedge



Inventory System – “Samples”

- Simple sample inventory system,
- What is it, where is it
- Low cost (next step up is x2-3 more expensive)
- UK based support
- Integrates well with Ziath scanners



Future products – Lux (Q2 release)

- Fully portable
- Take down to the freezers
- Long Battery
- Internal circuit board we created
- Internal save, USB, External Save (network)
- Better than a battery on a trolley!

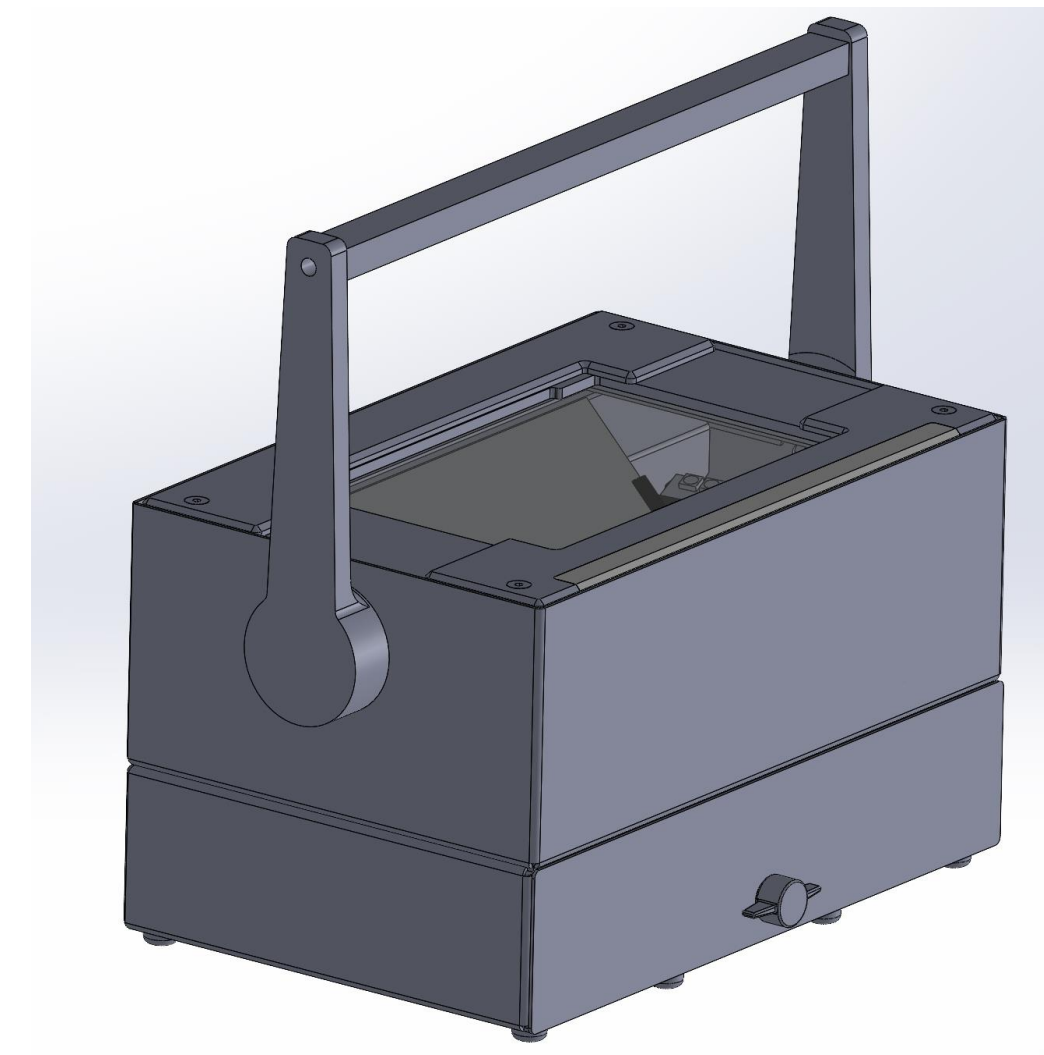

FUTURE PRODUCT – Ritrack (Q3 RELEASE)

- Special RFID chip
- Magnetic RAM with unlimited rewrites
- Use ‘insertor’ tool to place chip into any rack
- Run image and put data onto the RFID tag



DP5 Scan

Export To... Send to Email Export to RITrack Save image...

Interactive View RITrack View **List View** Table View

#	Tube Barcode	Container ID	Row	Column	RITrack Container ID	RITrack Tube ID
A1	EMPTY	ALTO0000262	1	1	ALTO0000262	AL10023351
A2	ERROR	ALTO0000262	1	2	ALTO0000262	AL10022422
A3	EMPTY	ALTO0000262	1	3	ALTO0000262	AL10021325
A4	AL10023459	ALTO0000262	1	4	ALTO0000262	AL10023459
A5	EMPTY	ALTO0000262	1	5	ALTO0000262	AL10022892
A6	AL10021490	ALTO0000262	1	6	ALTO0000262	AL10021490
A7	AL10021497	ALTO0000262	1	7	ALTO0000262	AL10021497
A8	AL10022586	ALTO0000262	1	8	ALTO0000262	AL10022586
A9	AL10020535	ALTO0000262	1	9	ALTO0000262	AL10020535
A10	AL10023319	ALTO0000262	1	10	ALTO0000262	AL10023319
A11	AL10022554	ALTO0000262	1	11	ALTO0000262	AL10022554
A12	AL10022994	ALTO0000262	1	12	ALTO0000262	AL10022994
B1	EMPTY	ALTO0000262	2	1	ALTO0000262	AL10020529
B2	ERROR	ALTO0000262	2	2	ALTO0000262	AL10023855

Close

DP5 Scan

Export To... Send to Email Export to RITrack Save image...

Interactive View **RITrack View** List View Table View

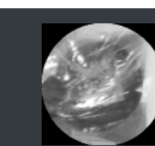

Container ID	ALTO0000262	RITrack Container ID	ALTO0000262
Position	A1		
Tube Barcode	EMPTY		
RITrack Tube ID	AL10023351	Details	

Auto export

	excel/csv	pdf	json	text	email	script	ritrack
	none	none	none	none	none	✓	none
	none	none	xml	image	database	url	none

Close

Common 2D Barcode Scanning Problems – Barcodes covered in Ice

- Samples from -80C freezer may be covered in ice
- Sponge and alcohol technique
- “Fogging” of the scanner window due to condensation
- Passive cryoprotection option



Common 2D Barcode Scanning Problems – Tubes placed in incompatible racks

- 2D barcoded tubes come in all shapes and sizes
- Manufacturer may not provide suitable racks
- If different tubes are placed in the racks, the base of the tube is higher above the glass
- Ensure holes are wide enough and distance isn't too far

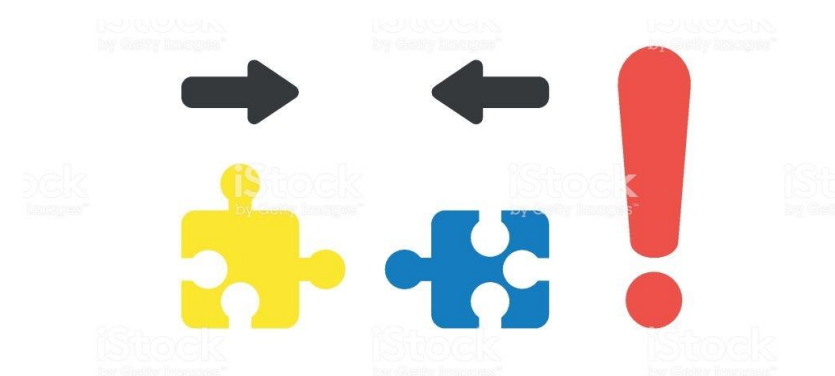

Common 2D Barcode Scanning Problems – Barcodes printed too close to tube edge

- All barcodes require a surrounding blank space – quiet zone
- Space – 2 modules (black+white pixels)
- Barcodes printed near edge of tube can impinge on this white space





Visit our booth tomorrow evening where we can show you these products at our booth and answer any questions that you may have.