

**AZENTA**  
LIFE SCIENCES

# EMEA Automated Stores and Cryo regions

Amrit Duhela, Sales Director EMEA, Automated Stores and Cryo

# The EMEA Team



**ADRIEN LECOCQ**

Sales manager Auto Cryo  
Based In France



**FRITZ KAISER**

Sales manager Auto Cryo  
Based in Germany



**TORSTEN HANSELL**

Sales manager Stores  
Based in the UK



**LESLEY SCOTT**

Sales manager Stores  
Based in the UK



**Charlie Knowles**

Sales Applications Engineer  
Based in the UK



**Lawerence Oakley**

Sales Applications Engineer  
Based in the UK

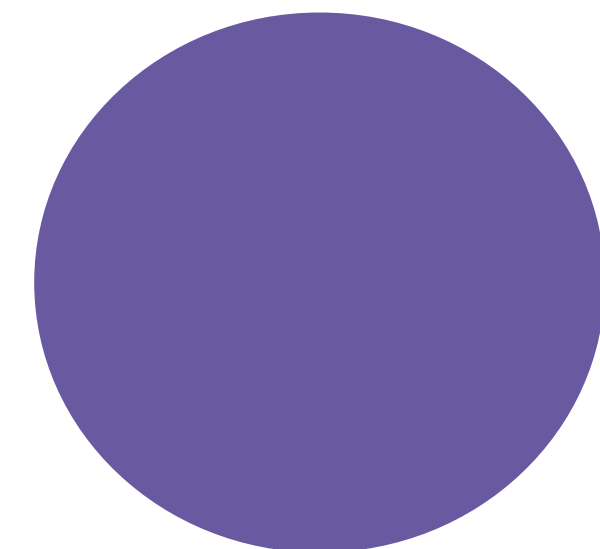

**Aaron Tattersal**

Service/Install lead Cryo EMEA  
Based in Germany

# Automated Stores and Cryo regions 2024

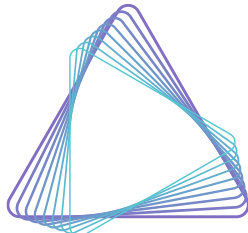

**AZENTA**  
LIFE SCIENCES

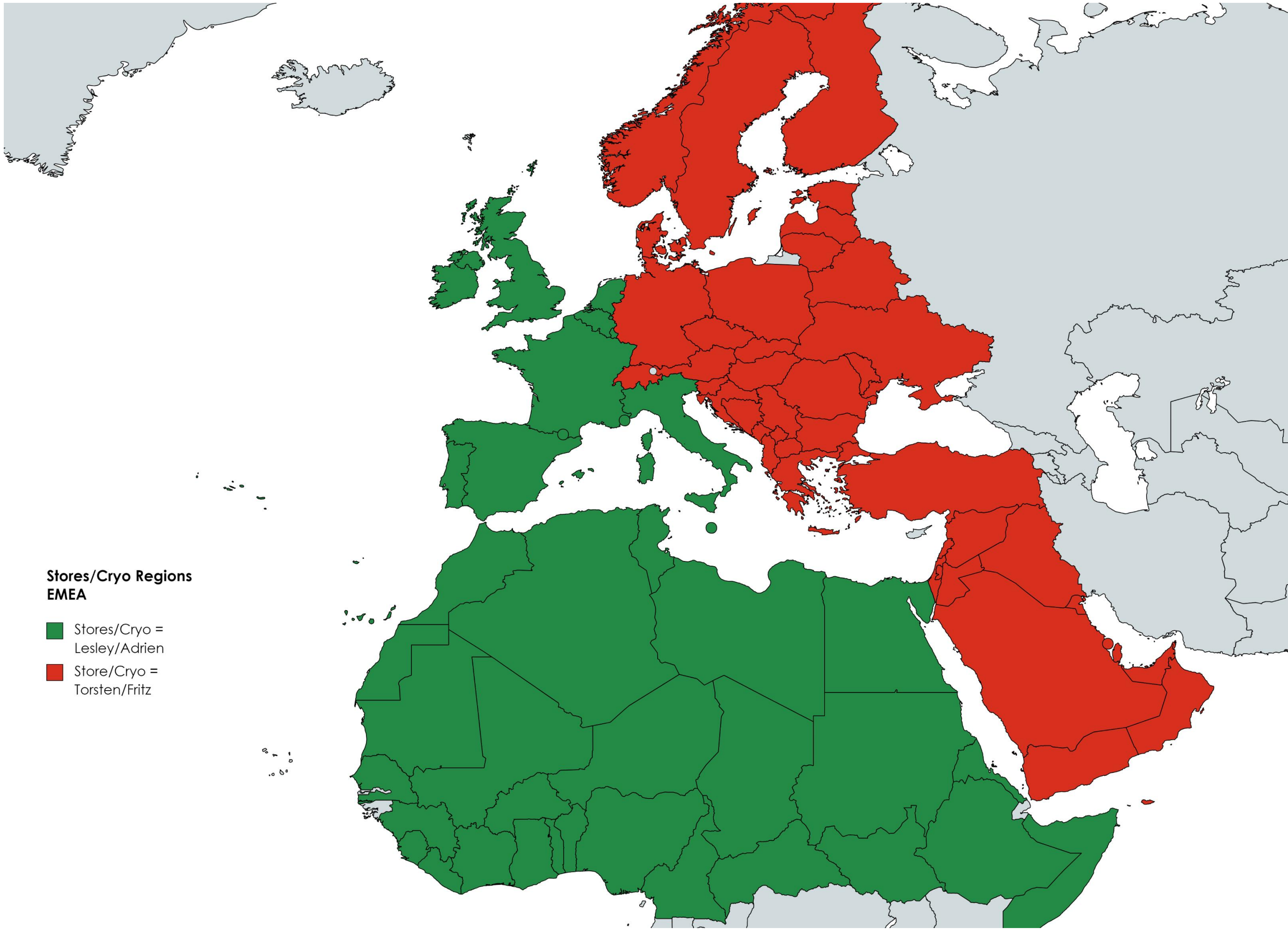

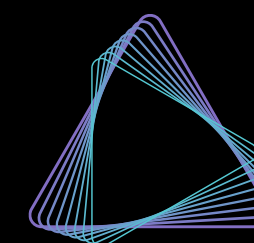

**AZENTA**  
LIFE SCIENCES

# CRYOGENIC STORAGE SYSTEMS TARGET MARKET

02

# Cryogenic Storage Solutions



## SOLUTIONS FOR EVERY STORAGE NEED

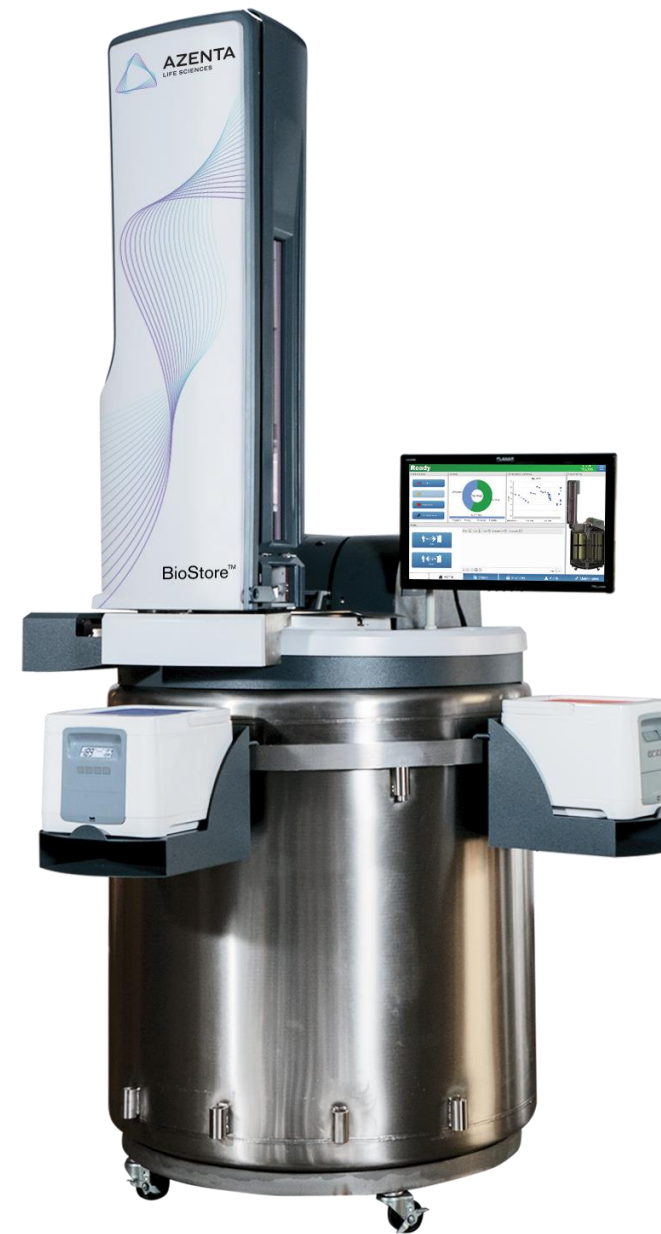

**CryoStore Manual**  
-190 °C Non-Automated  
Freezer

**CryoStore PICO**  
-190 °C Automated  
Storage System  
(A32)

**CryoStore**  
-190 °C Automated  
Storage System  
(M42/A45)

**CryoStore Max**  
-190 °C Automated  
Storage System  
(M60/A60)

**CryoPod™ Carrier &  
Filling Station**

# BioStore™ -190 Cryogenic Storage Solutions

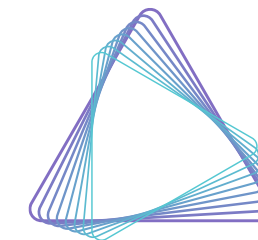

**AZENTA**  
LIFE SCIENCES

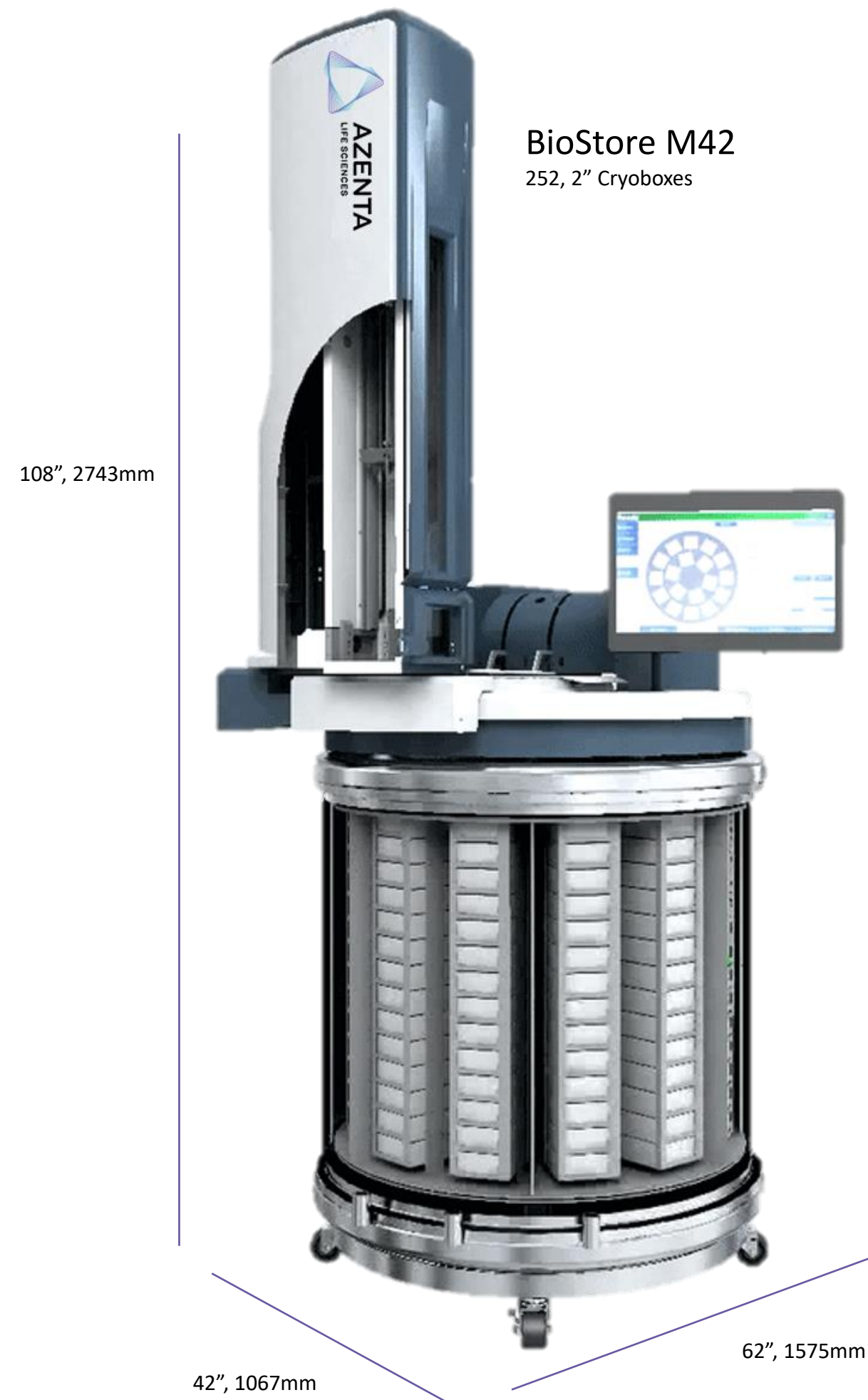
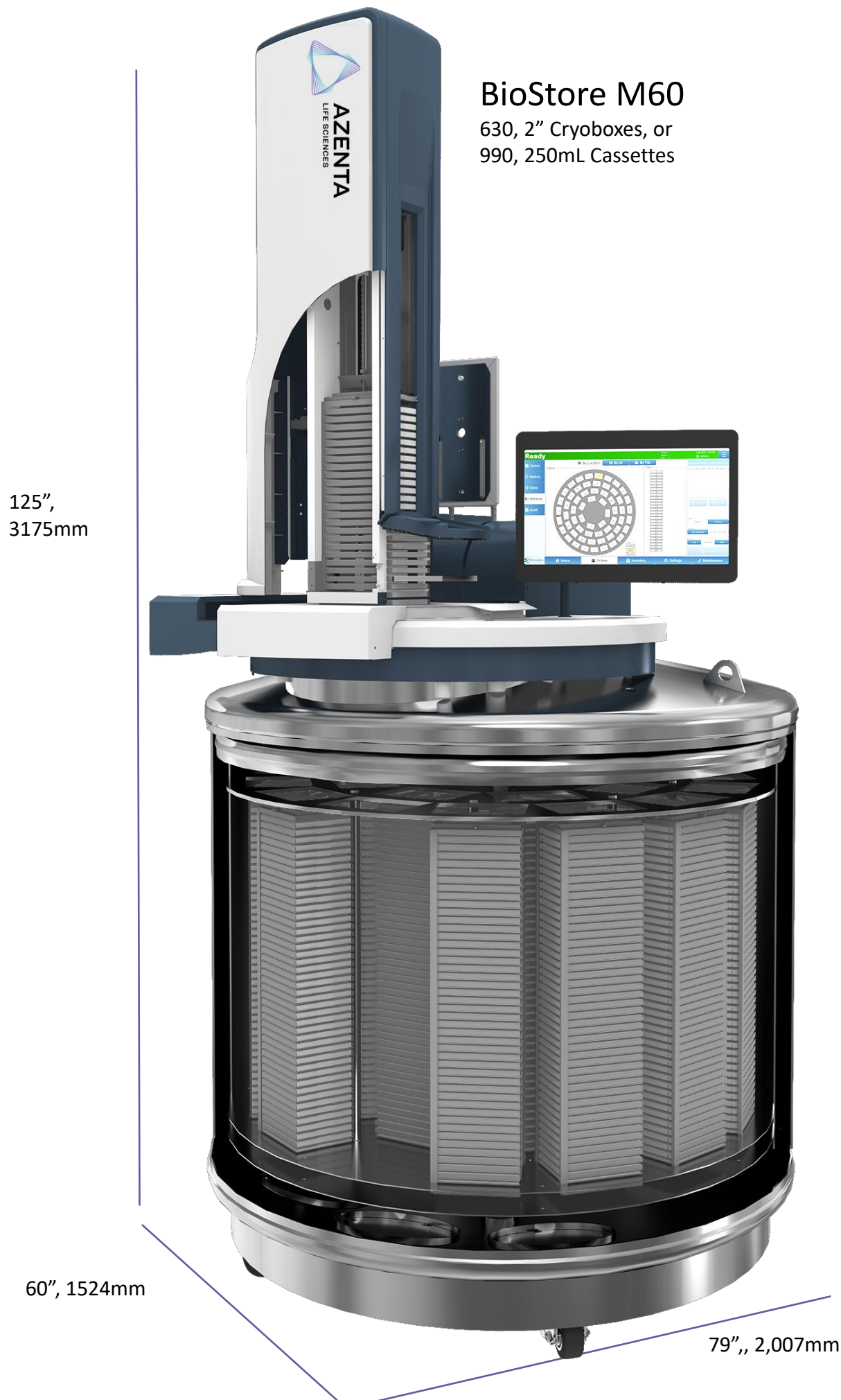

# Sample Capacity

BIOSTORE TYPE	FREEZER RACK TYPE	SLOTS	1ML AZENTA TUBES	2ML AZENTA TUBES
BioStore M42	2" CryoBox Racks	252	49,329 (196 tubes/box)	25,200 (100 tubes/box)
	2" SBS Racks	300	28,800 (96 tubes/box)	14,400 (48 tubes/box)
BioStore M60	2" CryoBox Racks	630	123,480 (196 tubes/box)	63,000 (100 tubes/box)
	2" SBS Racks	976	93,696 (96 tubes/box)	46,848 (48 tubes/box)
Pico	2" CryoBox Racks			8,800

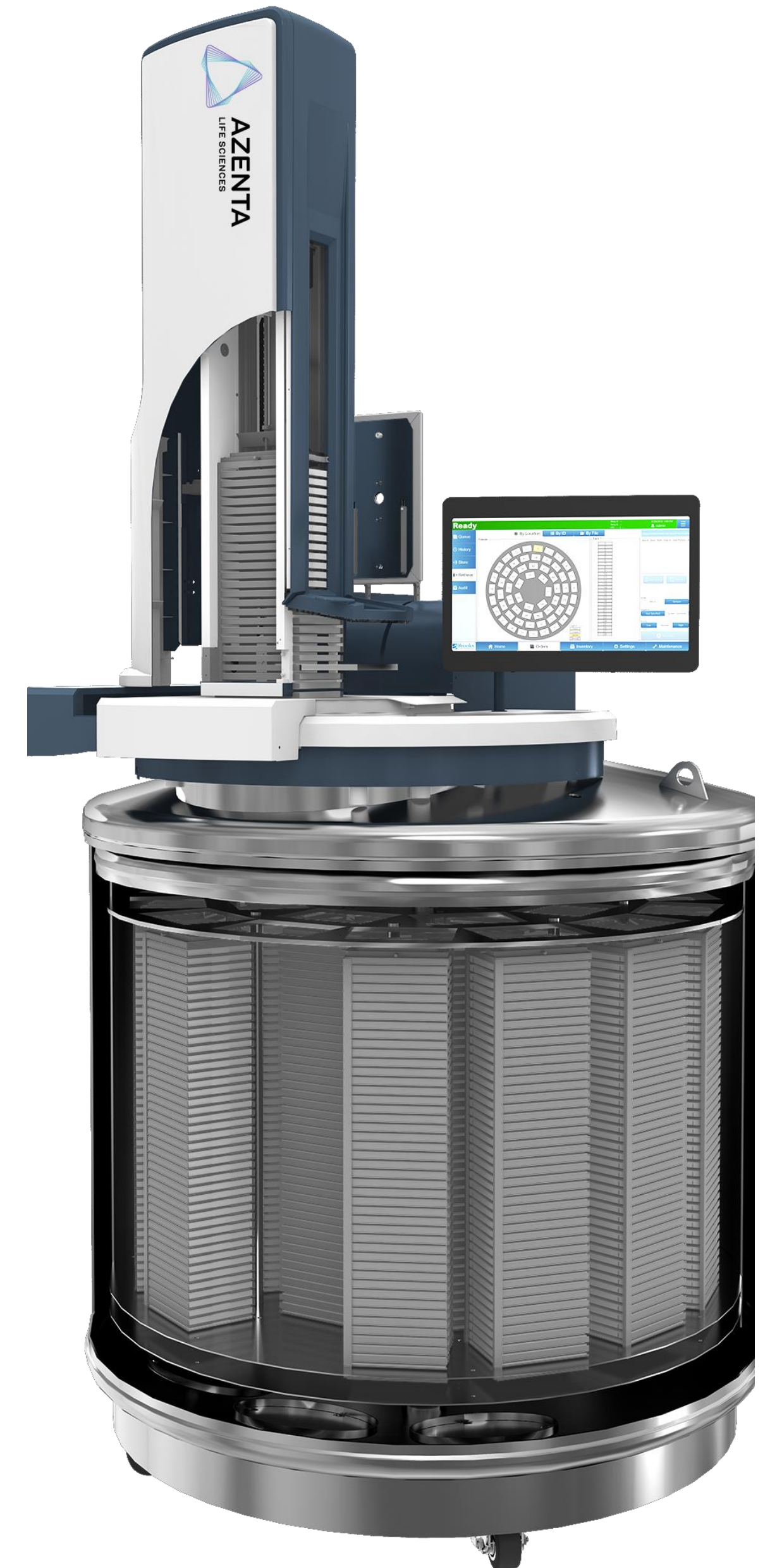

# Personas and Markets

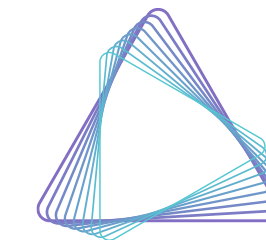

**AZENTA**  
LIFE SCIENCES

## Research

FEATURED



Human Cord Blood Mononuclear Cells,  
Frozen  
Primary human cells, frozen



## Pre-clinical to Commercial scale-up

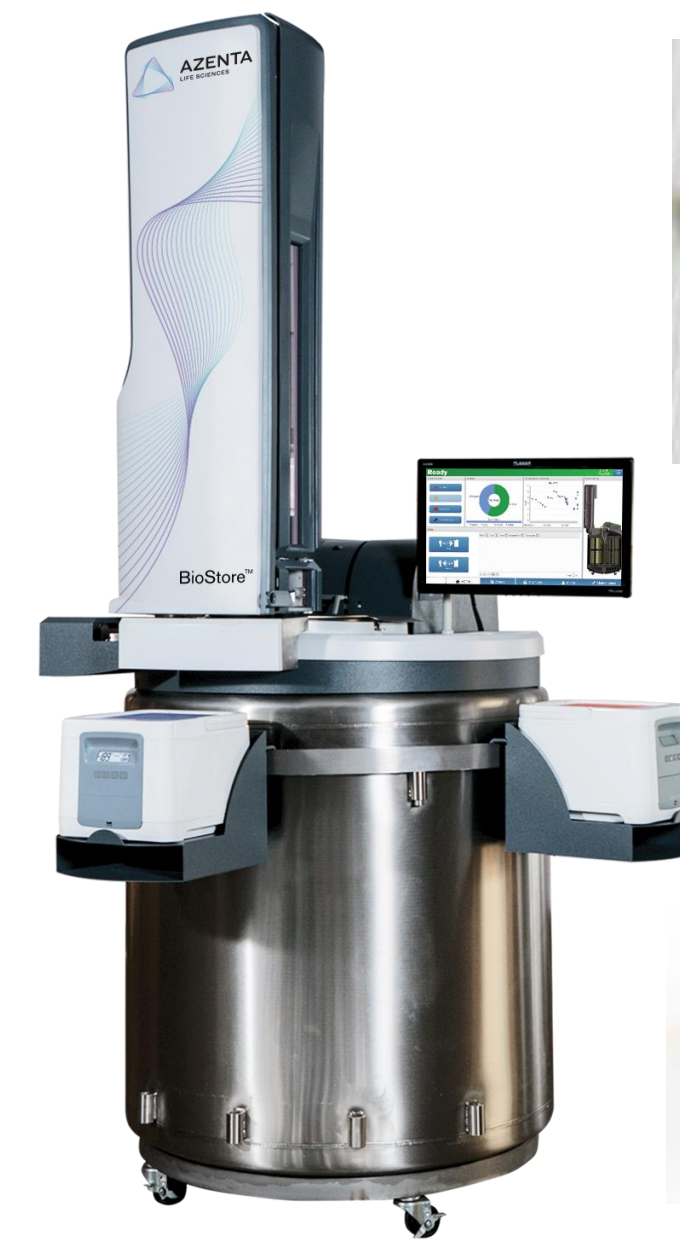



Research



## 4 Key R&D Sales Targets

- Cell line distributors
- Pharma and Biotech - cell line manufacturing
- Pharma and Biotech - research
- University research centers

*“I can supply 20 internal researchers with Cell Line ‘orders’ easily with B3C and Cryopod. What used to take over 80% of my time now only takes 10% of my time. I can re-allocate my time to the things I would rather be doing.”*

– Taylor Goldbeck

## Research



Replaced a -150C chest freezer and clipboard with a B3C as a shared unit for 40+ researchers, all with their own login and 3 boxes of vials

## Persona Attributes

- Un-regulated – It's Research and Discovery!
- Scientists with bioprocess focus
- Typically Low throughput / Small personal collections
- 'Open System' labware is most common
- Limited biobanking SOP training / understanding
- Cryo infrastructure needed, but not prioritized

Pre-clinical to Commercial scale-up

Clinical Sales Targets

- Key University Hospitals (GMP labs)
- CDMO (contract manufacturing)
- Pharma / Biotech
- 3<sup>rd</sup> Party Logistics (3PL)
- Point of Care

**Storing Critical Reagents**  
**QA/QC reference standard material**



# BioStore III Personas

## Today's Market

Research and Discovery

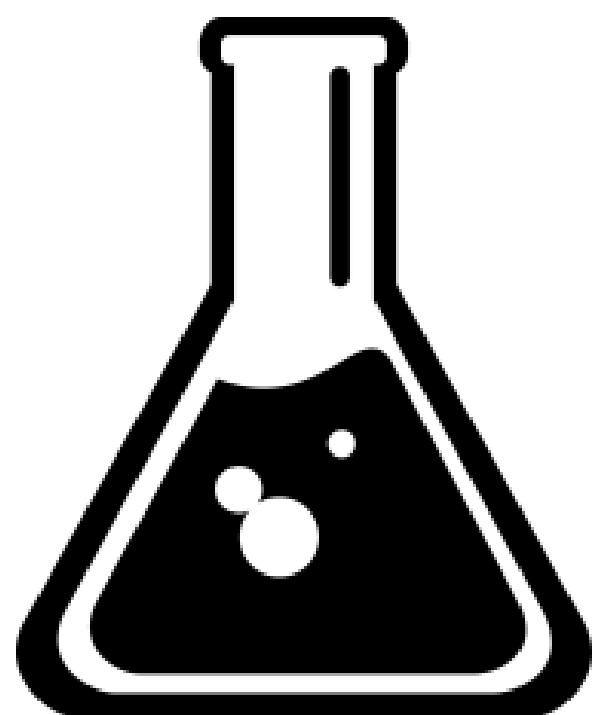

**Large CORE Biobank**

**Discovery Lab**

**Cell Line Distribution**

## Emerging Market

GMP Manufacturing

Cell Lab Near Hospital

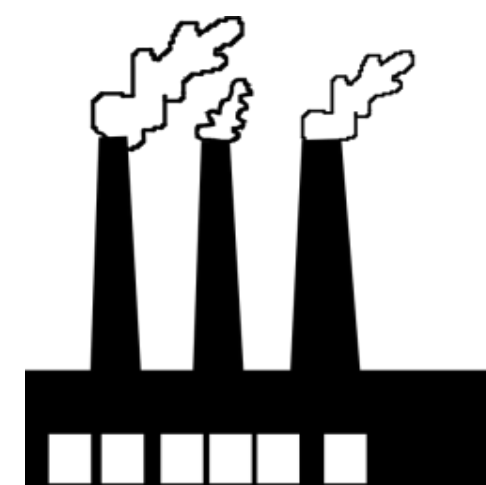

**Manufacturer**

**Hospital / Clinic**

# Customer Scenario: Abu Dhabi Stem Cells Center (UAE)



- Stem Cell and cellular therapies research and healthcare provider
- Founded in March/2019 with significant growth since then
- Existing sample collection and workflow supported through manual cryogenic storage

**ADSCC REQUIRED NEW STORAGE CAPACITY WITH LIMITED SPACE AND IMPROVED SAMPLE INTEGRITY AND FLEXIBILITY**

## CRYO STORE PICO KEY SELLING POINTS

- First step to introduce automated cryogenic storage systems
- Small system footprint to fit into the room
- Labware flexibility (1ml/2ml)



## Auto Cryo Sales by Market Segment

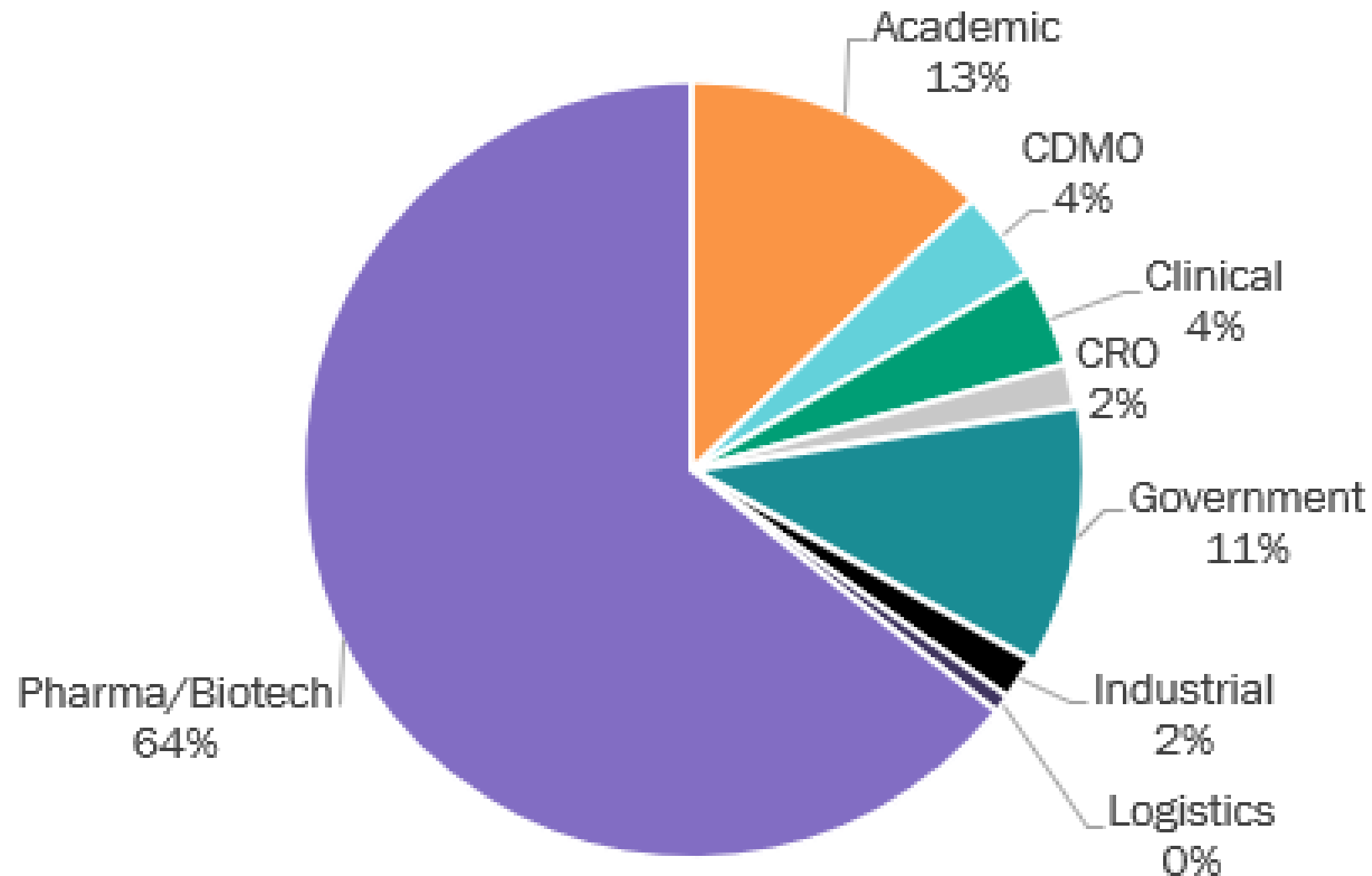

Strong sales presence in large pharma/biotech

- Opportunity in smaller pharma/biotech, academic/government spaces, and local CROs/CDMOs
- Limited opportunity in clinical settings due to EU MDR requirement

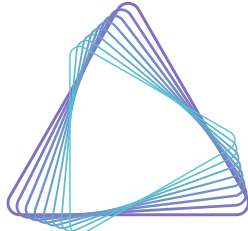

## Auto Cryo Sales by Application

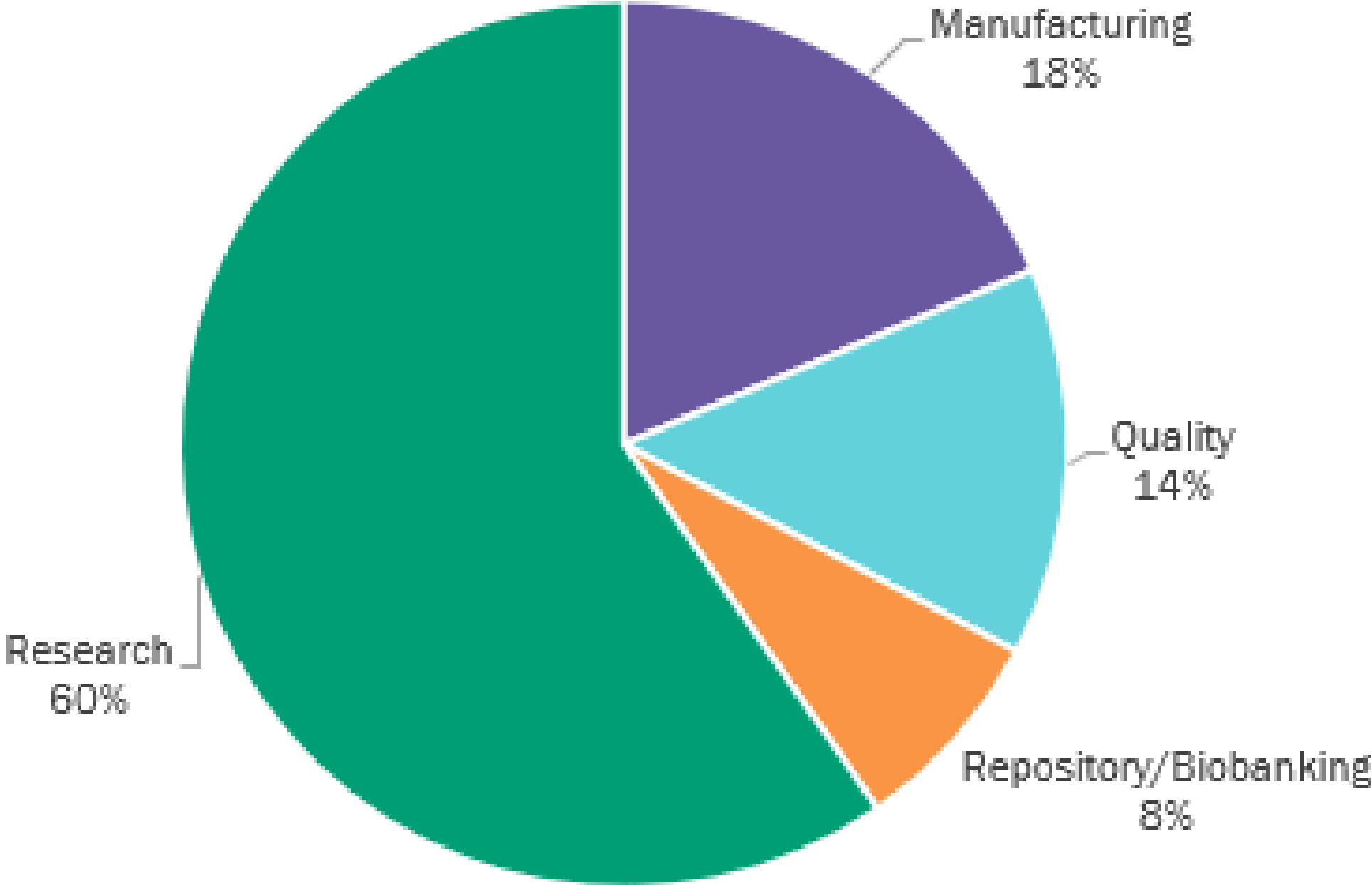

Strong presence in research across market segments, with room to grow in repository/biobanking applications

# Competitors



## GENERAL OVERVIEW

Auto cryo is a small industry with few large players, but is growing quickly

- Askion
- Haier Biomedical
- OriginCell
- Azenta Life Sciences (SRS)
- Smaller regional manufacturers

## AZENTA PROS

- Flexible and able to support many bags/cassettes as well as tubes and vials (SBS, Cryobox, or sterile)
- Overall system footprint
- Dedicated and proven global service team
- Price\*

## AZENTA CONS

- No tube picking option (cherry picking)

\*Price depends heavily on competitor, but generally tube picking systems cost more



## Value Prop: Auto Cryo for CGT

Azenta Life Sciences produces best-in-class cryogenic automation to streamline sample management so our customers can focus on bringing therapies to market faster. We secure critical quality attributes, substantially increase regulatory compliance, and deliver the safest user access to samples, in an automated and scalable manner. Available in expertly-curated bundles to offer a quick start setup for a seamless and efficient implementation.



Thank you

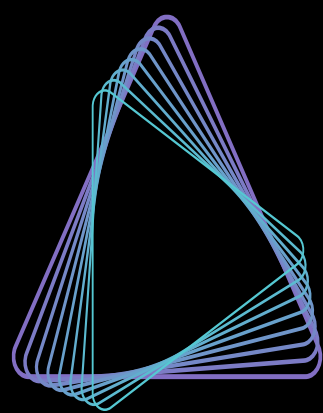

**AZENTA**  
LIFE SCIENCES

